

AR Remediation Plan - Point, Line, Line Segment, Ray and Angle- Identify, Describe, Classify, and Measure

Measuring Angles

STRAND: Measurement and Geometry

STRAND CONCEPT: Point, Line, Line Segment, Ray and Angle- Identify, Describe, Classify, and Measure

SOL 5.12

Remediation Plan Summary

Students define the term *angle* and classify a given angle as right, obtuse, acute, or straight.

Common Misconceptions

Students do not understand what part of the angle to measure. They think it is about the rays not the distance between the rays. They think the length of the ray is the size of the angle.

They also sometimes don't understand that a degree is actually $\frac{1}{360}$ of a circle.

Materials

"What I Know About _____" worksheets

"Index Card Angles" worksheets

3 x 5 inch index cards

Craft sticks

Colored paper

"Station Answers" worksheets

"Reflection" worksheets

Introductory Activity

Distribute the "What I Know About _____" worksheets. Write the word *angle* on the board, and have students fill in the blank at the top of the page with the word *angles*. Give students three to five minutes to write down everything they know or think they know about angles.

When time is up, put students in pairs to share and expand their personal lists. Have the pairs share their ideas with the whole class, and discuss what the students know about angles.

Record their responses on the board for everyone to see and add to their lists. Be sure to

discuss that a degree is actually $\frac{1}{360}$ of a circle and draw a picture to help students visualize

this.

Plan for Instruction

1. Distribute an "Index Card Angles" worksheet, an index card, and two craft sticks to every student.

AR Remediation Plan - Point, Line, Line Segment, Ray and Angle- Identify, Describe, Classify, and Measure

2. Explain to students that there are three types of angles and that they are going to create them, using the craft sticks and index cards. Explain each type of angle referring to the circle drawn in the warm-up activity (90 degrees is $\frac{1}{4}$ of a circle, 180 degrees is $\frac{1}{2}$ of a circle).
3. Continue to refer to this picture of the circle as steps 4,5,and 6 are completed in this plan.
4. Have students place their two craft sticks along the outside of the corners of the index card. This forms a right angle. Students may refer to the "Index Card Angles" worksheet for assistance. To help students remember what a **right angle** looks like, tell them the story of Roy and Rachel Right. In class, Roy and Rachel Right always have the right answer so they always raises their hand to answer the questions. Have students raise their hand to show the vertical ray of the right angle.
5. Have students keep the horizontal craft stick in place and slant the vertical craft stick to the right. Students may use the "Index Card Angles" worksheet for assistance. Ask students if this angle is larger or smaller than the right angle. (smaller) Tell students the story of Annette and Andrew Acute. They were always worried about their appearance. They were so **cute** that they always had their hand in their hair making sure that they looked just perfect. Have students pretend to primp: this forms an **acute angle** with the elbow as the vertex.
6. Have students keep the horizontal craft stick in place and slant the vertical craft stick far to the left so that the angle takes up the index card and much more. Students may use the "Index Card Angles" worksheet for assistance. Ask if this angle is larger or smaller than the right angle. (larger) Tell students the story of Oliver and Olga Obtuse. They could never keep their hands to themselves. They were always busy bothering the student beside them. They would always reach over to tap that student on the shoulder. Have students reach out as if they were going to tap the person beside them on the shoulder: this forms an **obtuse angle** with the elbow as the vertex.
7. Have students keep the horizontal craft stick in place and place the other craft stick so the ends meet and form a straight line along the long edge of the index card.
8. Before class, print each "Station" sheet on a different colored sheet of paper, and place each sheet at a certain spot ("station") in the room. Give a "Station Angles" worksheet to each student. Have students take turns going to each station and classifying each angle as right, acute, obtuse or straight. Show them how to do this by placing the corner of their index card on the vertex of the angle and comparing whether the angle is smaller than, larger than, or exactly the same as a right angle.
9. Check answers as each student completes the task.

Pulling It All Together (Reflection)

Have students complete the "Reflection" worksheet.

Note: The following pages are intended for classroom use for students as a visual aid to learning.

Name: _____

What I Know About _____

Here's what I know about _____ :

1. _____
2. _____
3. _____
4. _____
5. _____
6. _____
7. _____
8. _____
9. _____
10. _____
11. _____
12. _____
13. _____
14. _____
15. _____
16. _____
17. _____
18. _____
19. _____
20. _____

Name: _____

Index Card Angles

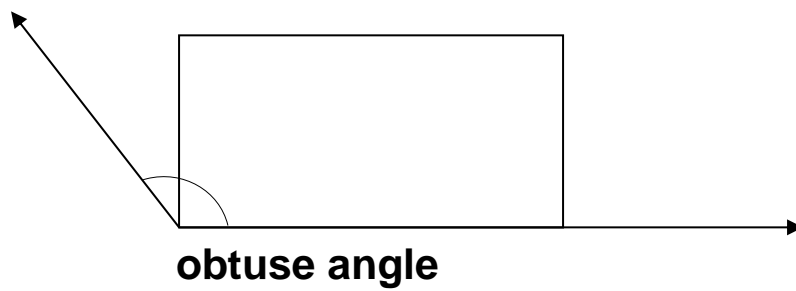
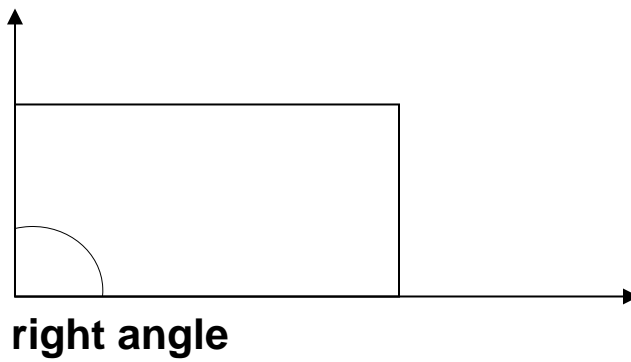
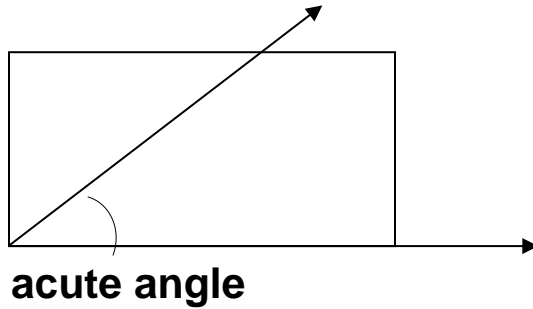

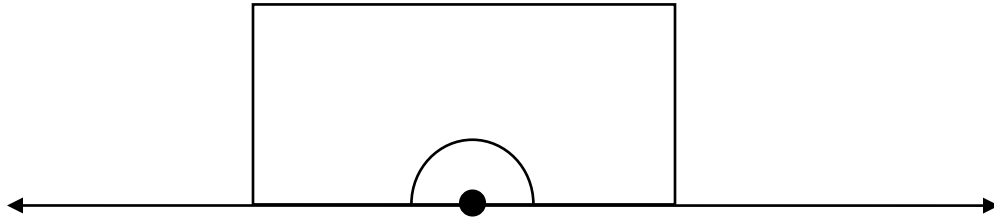

straight angle

Station 1

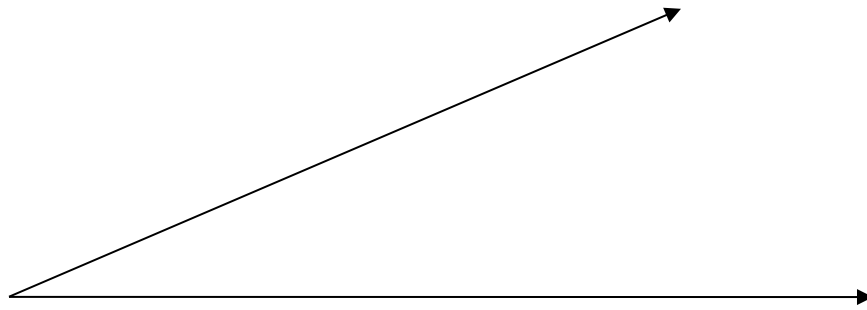

Station 2

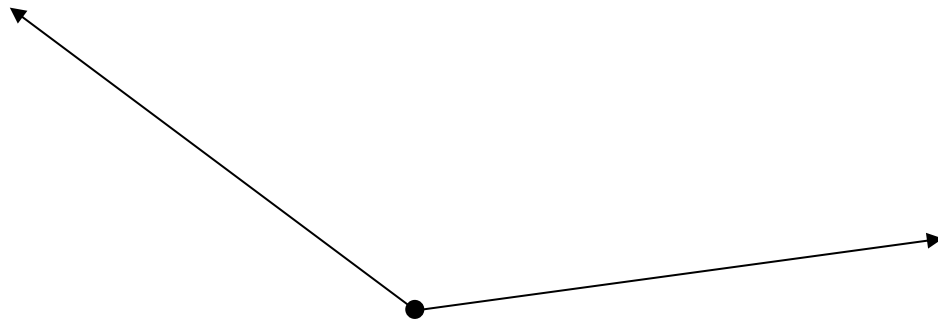

Station 3

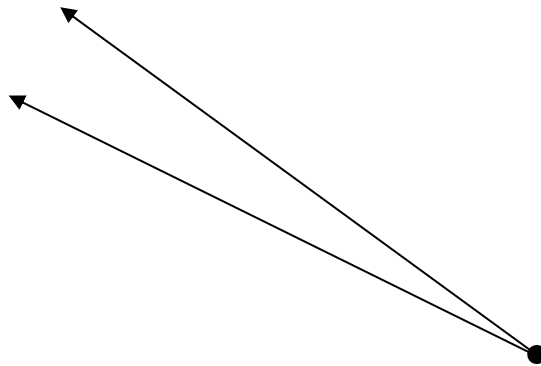

Station 4

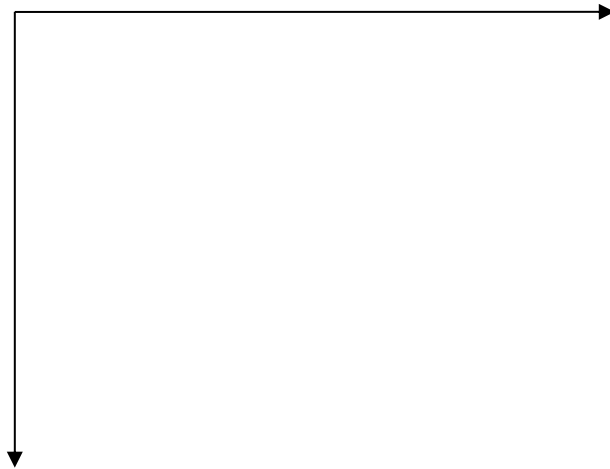

Station 5



AR Remediation Plan - Point, Line, Line Segment, Ray and Angle- Identify, Describe, Classify, and Measure

Name: _____

Station Angles

At each station, measure the angle, and decide if it is an acute, obtuse, a right, or straight angle. Write down the type of angle and the angle measurement.

Station 1

Station 2

Station 3

Station 4

Station 5

Name: _____

Reflection

1. The analog clock shows the time 8:22. What type of angle do the hands of the clock make?

2. Draw a straight angle and label the vertices M, Q, Z.



3. If the time on an analog clock is 11:55, what type of angle do the hands form?